

Rothe Erde® Turntables for vehicle trailers. Brochure LK 254/14.

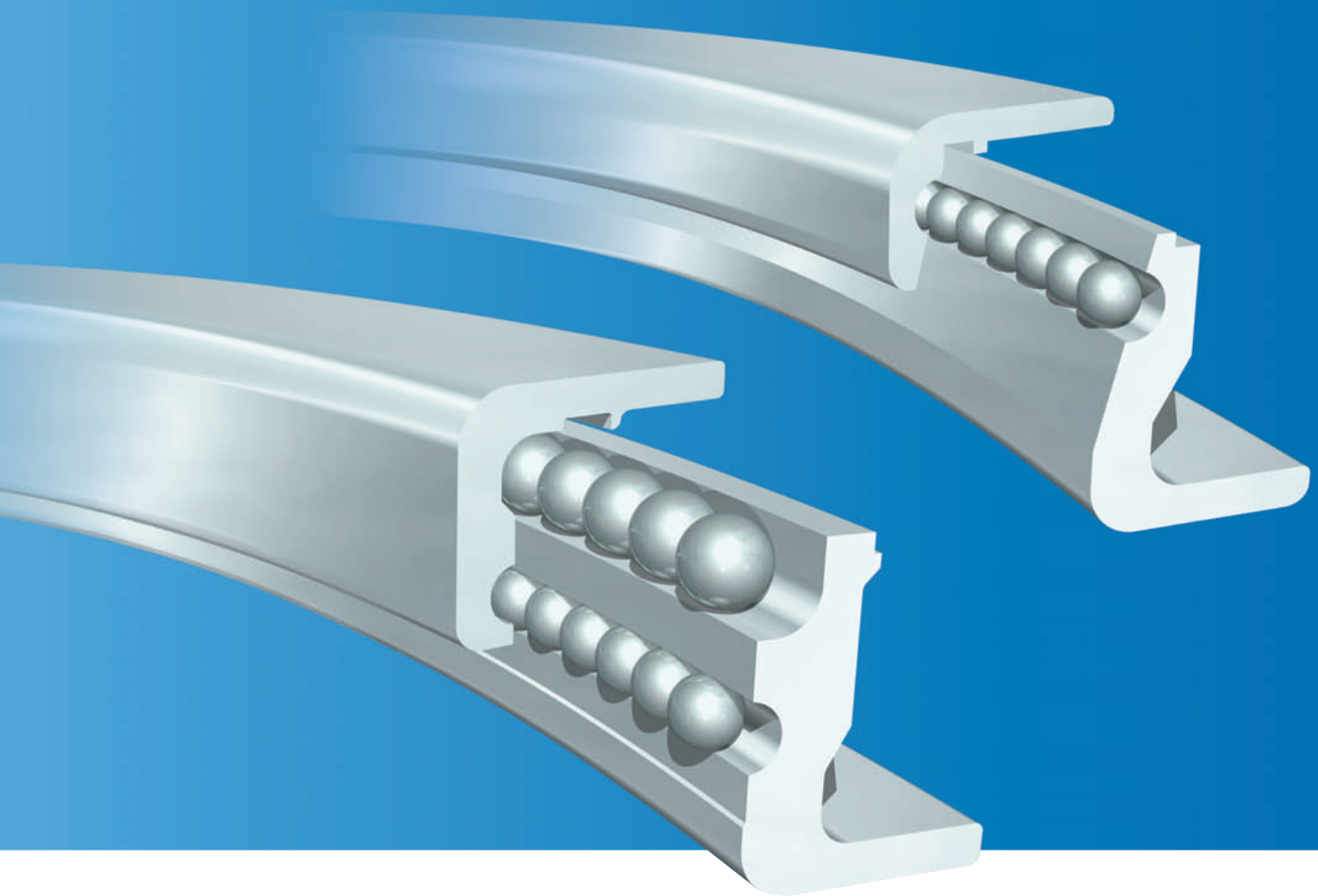

A ThyssenKrupp
Technologies
company

Rothe Erde



ThyssenKrupp

Rothe Erde. Technology Made-to-measure.

Our product range comprises ball and roller bearings, turntables and seamless rolled rings made from steel and non-ferrous metals.

We at Rothe Erde put quality first. All our activities from application engineering to design and production including comprehensive customer service are based on the DIN/ISO 9001/2000 standard of quality.

Rothe Erde Turntables – Products of proven quality

Rothe Erde turntables have been developed exclusively for installation in vehicle trailers. Their purpose is to transmit both the axial load, thrust and traction forces.

The standard series turntables shown in this brochure are the result of many years' design and manufacturing experience in the field of bogie steering systems.

Rothe Erde turntables are built to the highest manufacturing standards and are designed to meet extremely high performance requirements.

Each turntable consists of two steel rings designed for flange mounting. The raceways are machined so as to ensure that the load transmission is favourably directed between the antifriction bearing steel balls that are fitted. An initial filling of grease protects the raceway system.



Bearing Configurations and Bearing Tables. Types 16 L · 16 · 80

Type 16 L
capable for farm
trucks and carts
of up to 25 km/h

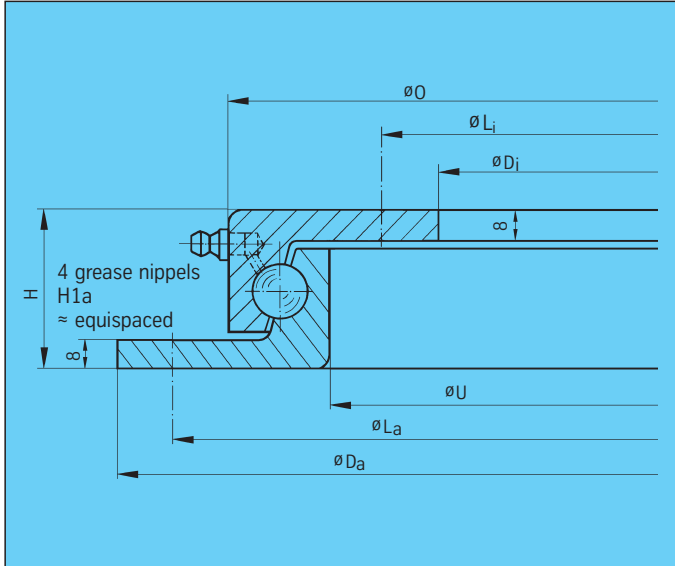

Type 16
capable for light
goods vehicle
trailers and farm
trucks of over
25 km/h

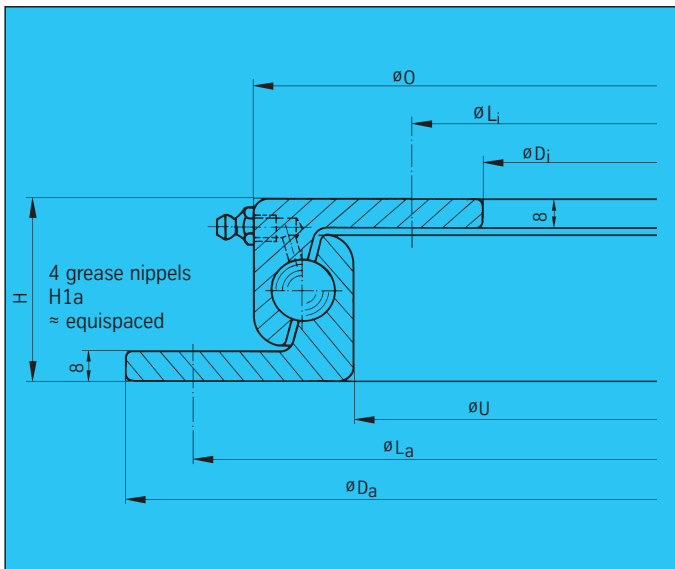

Type 80
capable
for two- and
three-axle trailers
of over 25 km/h

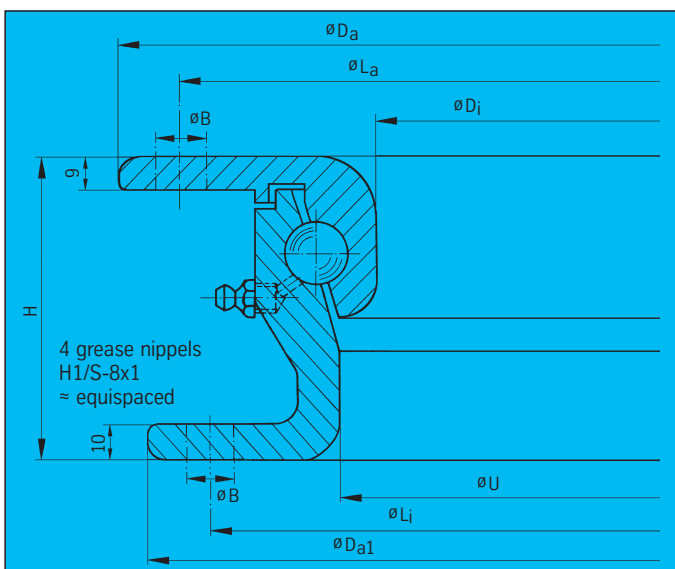

Drawing Number · Type

310.16.0300.000 · Type 16 L/400

310.16.0400.000 · Type 16 L/500

310.16.0500.000 · Type 16 L/650

310.16.0600.000 · Type 16 L/750

310.16.0700.000 · Type 16 L/850

310.16.0800.000 · Type 16 L/950

310.16.0900.000 · Type 16 L/1050

320.16.0400.000 · Type 16/500

320.16.0500.000 · Type 16/650

320.16.0600.000 · Type 16/750

320.16.0700.000 · Type 16/850

320.16.0800.000 · Type 16/950



320.16.0900.000 · Type 16/1050

330.16.0500.000 · Type 80/685

330.16.0700.010 · Type 80/880

330.16.0900.000 · Type 80/1000

330.16.1000.010 · Type 80/1090

Race track diameter D_L [mm]	Weight (approx.) [kg]	Outer diameter D_a [mm]	Inner diameter D_i [mm]	Overall height H [mm]	Outer hole circle diameter L_a [mm]	Inner hole circle diameter L_i [mm]	Bore diameter B [mm]	Number of grease nipples n_1	Diameter Da_1 [mm]	Diameter O [mm]	Diameter U [mm]	Ball diameter d [mm]	Permissible axial load*		Bearing clearances up to	
													 2 axles [kN]	 more than 2 axles [kN]	axial [mm]	radial [mm]
320	11	404	236	42	375	260	–	4	–	346	294	16	7.5	–	1.1	0.7
420	15	504	336	42	475	360	–	4	–	446	394	16	9.0	–	1.1	0.7
570	20	654	486	42	625	510	–	4	–	596	544	16	15.0	–	1.1	0.7
670	23	754	586	42	725	610	–	4	–	696	644	16	18.0	–	1.1	0.7
770	27	854	686	42	825	710	–	4	–	796	744	16	25.0	–	1.1	0.7
870	30	954	786	42	925	810	–	4	–	896	844	16	30.0	–	1.1	0.7
970	34	1054	886	42	1025	910	–	4	–	996	944	16	35.0	–	1.1	0.7
408	17	500	315	48	475	340	–	4	–	434	381	16	18.0	–	1.0	0.7
558	23	650	465	48	625	490	–	4	–	584	531	16	25.0	–	1.0	0.7
658	26	750	565	48	725	590	–	4	–	684	631	16	30.0	–	1.0	0.7
758	30	850	665	48	825	690	–	4	–	784	731	16	35.0	–	1.0	0.7
858	34	950	765	48	925	790	–	4	–	884	831	16	40.0	–	1.0	0.7
958	39	1050	865	48	1025	890	–	4	–	984	931	16	45.0	–	1.0	0.7
599	38	721	567	80	671	657	–	4	696	–	583	16	35.0	30.0	1.0	0.7
794	48	916	762	80	866	852	16	4	891	–	778	16	55.0	50.0	1.0	0.7
914	58	1036	882	80	984	970	–	4	1011	–	898	16	65.0	60.0	1.0	0.7
1004	63	1126	972	80	1074	1060	18	4	1101	–	988	16	70.0	65.0	1.0	0.7

* For different axle combinations, please contact us.

Bearing Configurations and Bearing Tables.

Types 90 · 90 WA · 90 S

Type 90
capable for two-
and three-axle
trailers of over
25 km/h

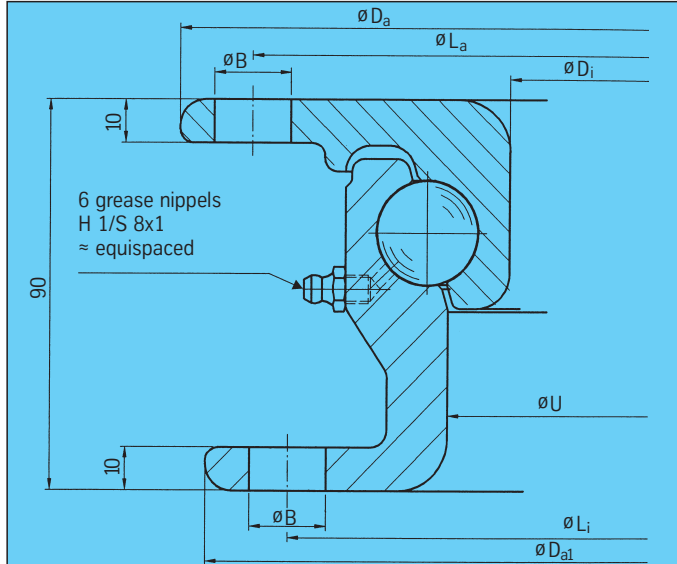

Type 90 WA
capable for two-
and three-axle
trailers of over
25 km/h

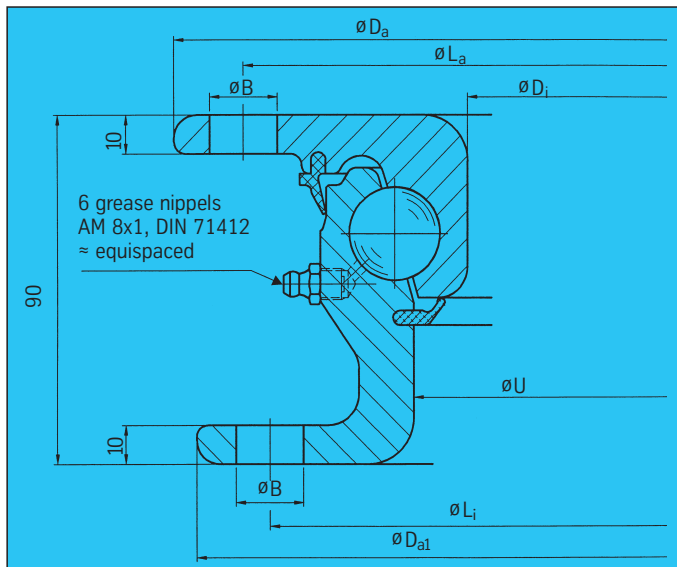

Type 90 S
capable for two-
and three-axle
trailers of over
25 km/h

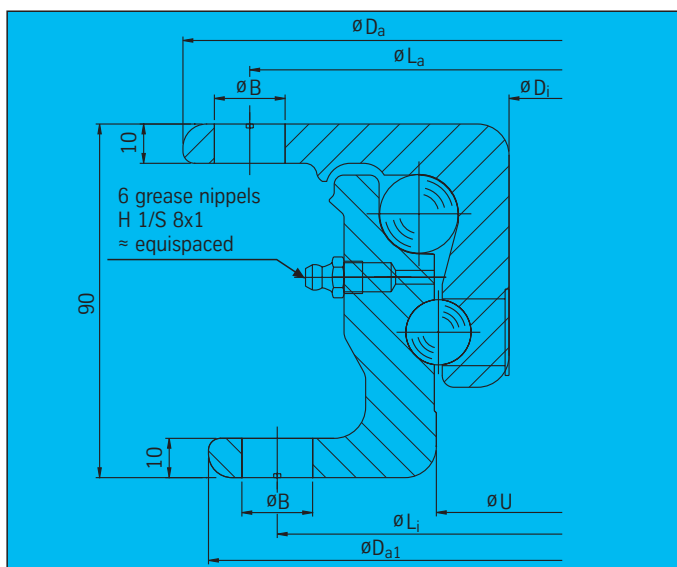

Drawing Number · Type

360.18.0800.000 · Type 90/1000.18

360.20.0800.000 · Type 90/1000.20

360.22.0800.000 · Type 90/1000.22

360.24.0800.000 · Type 90/1000.24

360.18.0900.010 · Type 90/1100.18

360.20.0900.010 · Type 90/1100.20

360.22.0900.010 · Type 90/1100.22

360.24.0900.010 · Type 90/1100.24

360.22.1000.010 · Type 90/1200.22

360.24.1000.010 · Type 90/1200.24

360.22.1100.010 · Type 90/1300.22

360.22.0955.010 · Type 90/1100.22 WA

360.24.0955.010 · Type 90/1100.24 WA

360.22.1055.010 · Type 90/1200.22 WA

360.24.1055.010 · Type 90/1200.24 WA

360.22.1155.010 · Type 90/1300.22 WA

370.20.0804.010 · Type 90 S/1000

370.20.0904.010 · Type 90 S/1100



370.20.1004.010 · Type 90 S/1200

370.20.1004.030 · Type 90 S/1200.12

370.24.1004.010 · Type 90 S/1200 SP

Type 90 WA – low-maintenance turntables

- Raceway systems protected by seals at upper and lower bearing gaps.
- Maintenance-free for a minimum of 3 years or a mileage of 300,000 kms

Race track diameter D_L [mm]	Weight (approx.) [kg]	Outer diameter D_a [mm]	Inner diameter D_i [mm]	Overall height H [mm]	Outer hole circle diameter L_a [mm]	Inner hole circle diameter L_i [mm]	Bore diameter B [mm]	Number of grease nipples n_1	Diameter D_{a1} [mm]	Diameter O [mm]	Diameter U [mm]	Ball diameter d [mm]	Permissible axial load*		Bearing clearances up to	
													 2 axles [kN]	 2 axles more than [kN]	axial [mm]	radial [mm]
894	64	1008	854	90	974	960	–	6	1000	–	885	18	75.0	70.0	1.0	0.7
894	64	1008	854	90	974	960	–	6	1000	–	885	20	90.0	80.0	1.0	0.7
894	64	1008	854	90	974	960	–	6	1000	–	885	22	110.0	100.0	1.0	0.7
894	64	1008	854	90	974	960	–	6	1000	–	885	24	160.0	140.0	1.0	0.7
994	71	1108	954	90	1074	1060	18	6	1100	–	985	18	90.0	80.0	1.0	0.7
994	71	1108	954	90	1074	1060	18	6	1100	–	985	20	110.0	100.0	1.0	0.7
994	71	1108	954	90	1074	1060	18	6	1100	–	985	22	130.0	120.0	1.0	0.7
994	71	1108	954	90	1074	1060	18	6	1100	–	985	24	180.0	160.0	1.0	0.7
1094	79	1208	1054	90	1174	1160	18	6	1200	–	1085	22	160.0	140.0	1.0	0.7
1094	79	1208	1054	90	1174	1160	18	6	1200	–	1085	24	200.0	180.0	1.0	0.7
1194	87	1308	1154	90	1274	1260	18	6	1300	–	1185	22	180.0	160.0	1.0	0.7
994	71	1108	954	90	1074	1060	18	6	1100	–	985	22	130.0	120.0	0.8	0.6
994	71	1108	954	90	1074	1060	18	6	1100	–	985	24	180.0	160.0	0.8	0.6
1094	79	1208	1054	90	1174	1160	18	6	1200	–	1085	22	160.0	140.0	0.8	0.6
1094	79	1208	1054	90	1174	1160	18	6	1200	–	1085	24	200.0	180.0	0.8	0.6
1194	87	1308	1154	90	1274	1260	18	6	1300	–	1185	22	180.0	160.0	0.8	0.6
880/ 870	82	1000	834	90	966	952	18	6	987	–	871	20/16	160.0	160.0	1.0	0.7
988/ 978	92	1108	942	90	1074	1060	18	6	1095	–	979	20/16	200.0	200.0	1.0	0.7
1088/1078	101	1208	1042	90	1174	1160	18	6	1195	–	1079	20/16	200.0	200.0	1.0	0.7
1088/1078	101	1208	1042	90	1174	1160	18	6	1195	–	1079	20/16	200.0	200.0	1.0	0.7
1087/1078	101	1208	1042	90	1174	1160	18	6	1195	–	1079	24/16	300.0	300.0	1.0	0.7

* For different axle combinations, please contact us.

under normal operating conditions.
Should exceptional environmental conditions prevail resp. should the turntable be directly cleaned with a high-pressure equipment it is necessary to regrease the turntable untimely.

- Regreasing is necessary after the maintenance-free operating period has elapsed.
- Torque:
Due to the double seal at the bearing gaps, a somewhat increased torque may

develop in comparison with the normal version. Operation is not impaired by this.

- Mounting dimensions, permissible loads, weights and drilling patterns are as for the standard design type 90.

Delivery.

Delivery

The turntables are supplied as either undrilled or drilled bearings with the standard type being filled with lithium-saponified grease of penetration grade 2 and the low-maintenance type with Gleitmo 585 K.

The turntables are provided with a preservation.

This preservation is only a temporary protection against corrosion which can principally be overpainted with all commercial finishing paints (as there are acrylic resins, 1-component and 2-component acrylic varnishes, 2-component PU-varnishes, combination cellulose nitrate lacquers, PVC-varnishes, 2-component epoxy varnishes) and bituminous paints.

Without pretreatment of the substrate – sandblasting for example - the applied protective painting does not provide an improved protection against corrosion, in connection with finishing paints either.

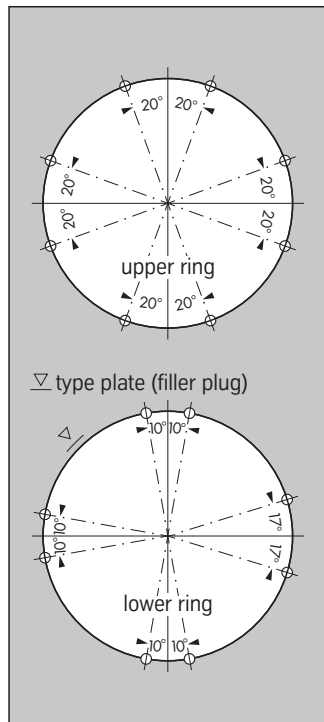
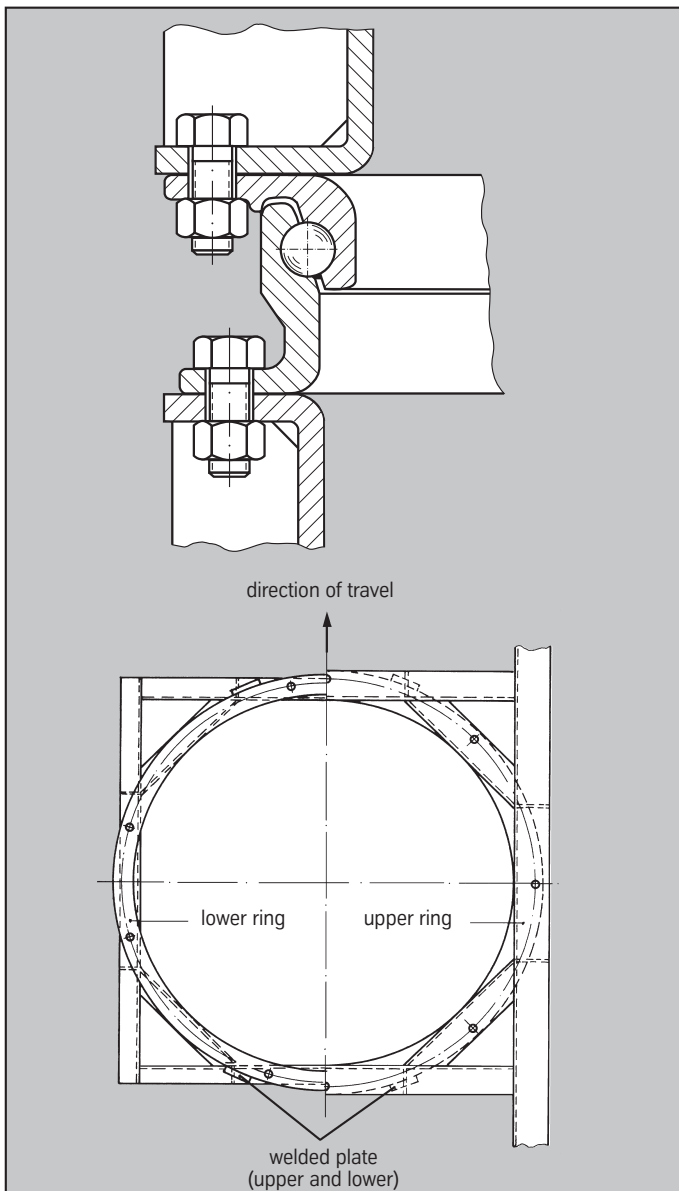

Type: 80/880

Hole diameter 16 mm.

Special drill holes upon request.

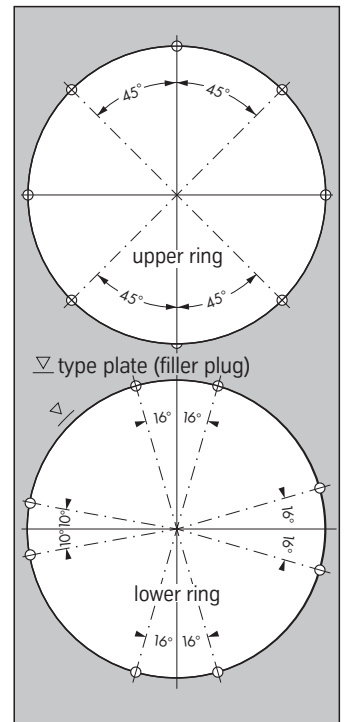

Types: 80/1090,

90/1100.18 to

90/1300.22,

Hole diameter 18 mm.

Special drill holes upon request.

Mounting Holes

If the customer drills the mounting holes himself, the type plate (filler plug) must be offset to the direction of travel by approx. 45° (for types 90 S and 90 WA inside at the upper ring). Mounting holes are not allowed in the area around the type plate.

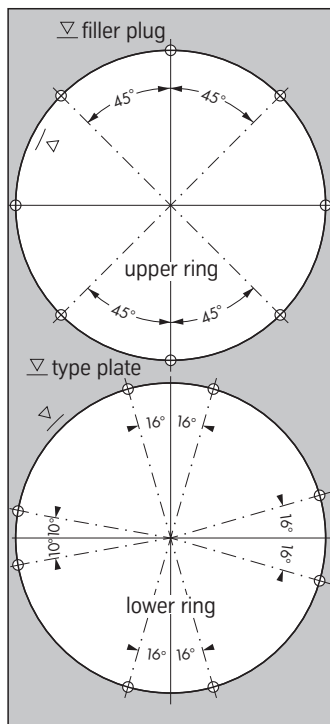

Types: 90/1100.22 WA to 90/1300.22 WA
Hole diameter 18 mm.
Special drill holes upon request.

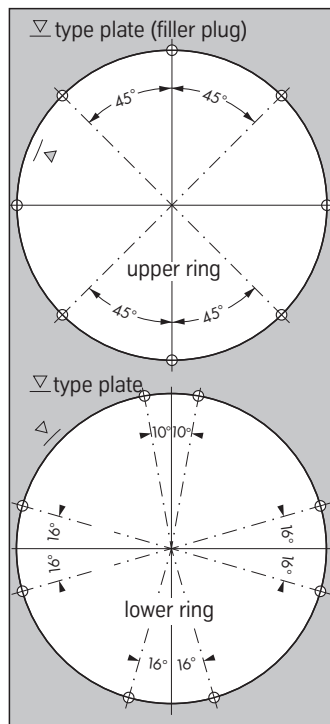

Types: 90 S/1000 90 S/1100 90 S/1200
Hole diameter 18 mm.
Special drill holes upon request.

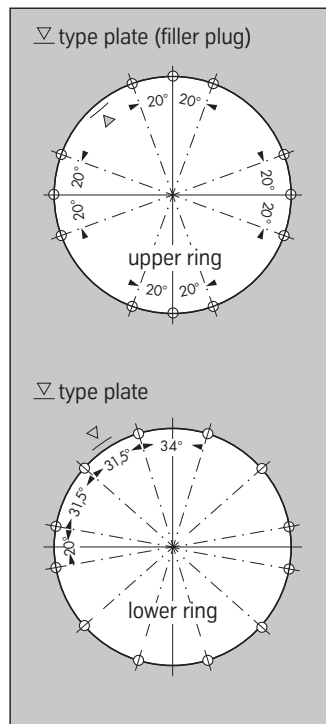

Types: 90 S/1200.12 90 S/1200 SP
Hole diameter 18 mm.
Special drill holes upon request.

Installation.

Installation

Turntables must be mounted on the flattest and most distortion proof structure possible. It is essential that at least 50% of the peripheral surfaces of the flanges are supported load bearing zones and that these latter are roughly equispaced in the direction of travel and at right angles to this.

The essential factor here is to support the profiled webs of the turntable, thus assuring direct force transmission into the ball raceways. Total out-of-flatness 1.3 mm, permissible are for example 0.8 mm up and 0.5 mm down. Larger out-of-flatnesses have to be compensated by suitable measures (machining of the contact surfaces or captive shims in the respective contact area).

The turntable must be fastened using at least 8 Grade 8.8 bolts per ring. The bolt locking system must comply with the TÜV's (German Technical Control Board's) requirements or with the prevailing approval regulations.

The horizontal forces resulting from acceleration or deceleration must be transmitted by plates welded to the mating structures so as to relieve the load on the bolts in the radial direction.

To prevent distortion from occurring, turntables must never be welded on to their mating structures.

The load details and the bolt connection are only valid for operation on roads and under transport conditions as usual in West Europe.

Type	H	Flange thickness	D _a	D _{a1}	D _i	O	U
16 L/400 and 16 L/500	± 3	± 2.0	+8 -5	-	+4 -10	± 3	± 3
16 L/650 to 16 L/1050		± 1.5	+8 -4	-	+4 -10		
16/500	± 3	± 2.0	+8 -5	-	+4 -10	± 3	± 3
16/650 to 16/1050		± 1.5	+8 -4	-	+4 -10		
80/685 to 80/1090	± 3	± 1.5	+8 -4	+8 -4	± 3	-	± 3
90/1000.18 to 90/1300.22	± 3	± 1.5	+8 -4	+8 -4	± 3	-	± 3
90/1100.22 WA to 90/1300.22 WA	± 3	± 1.5	+8 -4	+8 -4	± 3	-	± 3
90 S/1000 to 90 S/1200 SP	± 3	± 1.5	-1.6	-1.6	± 3	-	± 3

Table of Tolerances

Lubrication and Maintenance. Special Applications.

Lubrication and Maintenance Type 90 Turntables

Prior to installation, the turntable must be regreased whilst turning the upper ring until a grease collar appears at all bearing gaps around the entire circumference. A penetration grade 2 lithium-saponified grease should be used for regreasing. Regreasing should also be carried out after installation, rotating the turntable to achieve uniform grease distribution. The intervals for relubrication and examination of the preload of the bolt connections are determined by the installation requirements and operating conditions. However, the turntable must be lubricated at least once a month (please observe traffic authority requirements, TÜV, etc.).

The "as-supplied" bearing clearances shown in the bearing tables may be allowed to increase through wear by a maximum of 3 mm axially and radially. Thereafter, the turntable must be replaced.

Maintenance Type 90 WA Turntables – low-maintenance turntables

Our 90 WA turntables are provided with long-term lubrication for a maintenance-free period of 3 years minimum or a mileage of 300,000 kms.

This service period can be extended by relubrication with Gleitmo 585 K (Fuchs Lubritech, Weilerbach).

In case of applications with extreme environmental conditions specific maintenance instructions have to be established.

The turntables are equipped with grease fittings. Regreasing is necessary after the maintenance-free operating period has elapsed.

The preload check of the bolt connections is to be specified according to the prevailing installation requirements and operating conditions (please observe traffic authority requirements, TÜV, etc.).

We recommend to perform a clearance check in conjunction with acceptance procedures by TÜV or other accredited testing agencies. If the measurement shows an axial or radial clearance in excess of 3 mm, the turntable will have to be replaced.

Special Applications

If Types 16, 80 or 90 turntables are installed in vehicles capable of reaching a speed of up to 25 km/h, the permissible axial load may be increased by approx. 40%, depending on the diameter of the turntable. Please contact us for more details.

Details of turntables for non-standard applications and load cases are available upon special request. Please also refer to our catalogue, "Rothe Erde Large Diameter Antifriction Bearings", KD 210 series.

The contents of this brochure and all the data given herein have been meticulously compiled and proof read.

However, we accept no responsibility for any errors or omissions.

We reserve the right to introduce design changes or additions resulting from any improvements which may be made.

Head Office

Rothe Erde GmbH

Tremoniastrasse 5-11
D-44137 Dortmund
Phone: +49 (2 31) 186 -0
Fax: +49 (2 31) 186 -25 00
E-mail: info.rotheerde@thyssenkrupp.com
Internet: www.rotheerde.com

Offices in Germany

Berlin

Rothe Erde GmbH
Geschäftsstelle Berlin
Wittestrasse 49
D-13509 Berlin
Phone: +49 (30) 43 09 18 68
Fax: +49 (30) 43 60 57 46
E-mail: gsberlin.rotheerde@thyssenkrupp.com

North

Rothe Erde GmbH
Geschäftsstelle Nord
Am Pferdemarkt 31
D-30853 Langenhagen
Phone: +49 (5 11) 7 25 35 69-0
Fax: +49 (5 11) 7 25 35 69-9
E-mail: gsnord.rotheerde@thyssenkrupp.com

South

Rothe Erde GmbH
Geschäftsstelle Süd
Am Ostkai 15
D-70327 Stuttgart
Phone: +49 (7 11) 3 27 79 19-0
Fax: +49 (7 11) 3 27 79 19-9
E-mail: gssued.rotheerde@thyssenkrupp.com

Subsidiaries

Brazil

Robrasa
Rolamentos Especiais
Rothe Erde Ltda.
Rua Lidia Blank, No. 48
BRA-CEP 09913-010, Diadema,
São Paulo
Phone: +55 (11) 40 55 84 00
Fax: +55 (11) 40 55 38 92
E-mail: robrasa@robrasa.ind.br
Internet: www.robrasa.ind.br

Great Britain

Roballo Engineering Co. Ltd.
Mill Hill
North West Industrial Estate
GB-Peterlee,
Co. Durham SR8 2HR
Phone: +44 (1 91) 5 18 56 00
Fax: +44 (1 91) 5 86 90 96
E-mail: info@roballo.co.uk
Internet: www.roballo.co.uk

Japan

Nippon Roballo Co., Ltd.
Fukide Bldg., 7th Floor
Toranomom 4-1-13
J-Minato-Ku/Tokyo
Zip: 1 05-00 01
Phone: +81 (3) 34 34 43 41
Fax: +81 (3) 34 34 43 40
E-mail: info@roballo.co.jp
Internet: www.roballo.co.jp

China

Xuzhou Rothe Erde Slewing
Bearing Co., Ltd.
Wanzhai, Northern Suburb,
VRC-Xuzhou 221007, Jiangsu
Phone: +86 (5 16) 7 76 71 70
Fax: +86 (5 16) 7 76 89 46
E-mail: xuzhou_rothe_erde@xreb.com
Internet: www.xreb.com

India

Rothe Erde GmbH
Liaison Office India
C-16, Bhagat Singh Marg
Off Prabhu Marg
Tilak Nagar
IND-Jaipur 302 004
Phone: +91 (1 41) 2 62 42 47
Fax: +91 (1 41) 2 62 42 30
E-mail: re_india@vsnl.net
Internet: www.rotheerdeindia.com

Spain

Roteisa
Rothe Erde Ibérica S.A.
Carretera Castellón, km. 7
Polígono Industrial „La Cartuja“
E-50720 La Cartuja Baja
(Zaragoza)
Phone: +34 (9 76) 50 04 80
Fax: +34 (9 76) 50 01 54
E-mail: roteisa@roteisa.es
Internet: www.roteisa.es

France

Roballo France S.à r.l.
30, Boulevard Bellerive
F-92566 Rueil Malmaison CEDEX
Phone: +33 (1) 41 39 00 90
Fax: +33 (1) 41 39 00 99
E-mail: contact@roballo-france.com

Italy

Rothe Erde-Metallurgica Rossi
S.p.A.
Viale Kennedy, 56
I-25010 Visano (Brescia)
Phone: +39 (0 30) 95 20 -1
Fax: +39 (0 30) 95 20 -3 00
E-mail: mri@rotheerde.it
Internet: www.rotheerde.it

USA

Rotek Incorporated
1400 South Chillicothe Rd.
P.O. Box 312
USA-Aurora, Ohio 44202
Phone: +1 (3 30) 5 62 40 00
Fax: +1 (3 30) 5 62 46 20
E-mail: sales@rotek-inc.com
Internet: www.rotek-inc.com

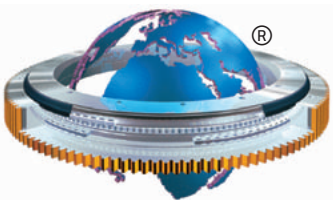

Rothe Erde